

TELEPHONE SETS—MODULAR TYPE

1. GENERAL

1.01 This section contains general information on the modular concept of telephone sets.

1.02 This section is reissued to:

- Add 158A cover
- Add 625FS and G25H connecting blocks
- Add 616W3 and 623D6 jacks
- Add 1A converter
- Add information on the 228-, 229-, and 230-type adapters
- Add caution information on the 267A adapter
- Add 227C, 227D, 248B, 281A, 282A, and 304A adapters
- Add information on routing of 523A-type plug leads used to convert nonmodular wall telephone sets to modular
- Add information on 635B connecting block
- Add information on D impact tool and 8762D-630 blade
- Add D8AA mounting cord
- Add 523A4B wall set plug
- Add AD3 and AC2P telephone base
- Add 220C, 226A, 2220C, and 2226A hand telephone sets
- Show 635A connecting block MD
- Show 227B and 248A adapters MD

- Show current production 630A4 connecting block

- Revise Tables A, C, F, G and Fig. 4, 5.

Since this reissue covers a general revision, arrows ordinarily used to indicate changes have been omitted.

1.03 The modular telephone set is the same as the standard telephone set except the telephone set base and handset are jack equipped to accept a plug-ended mounting cord (desk set) and handset cord (wall and desk sets). Modular wall sets are equipped with a plug to mount on a 630A4 connecting block.

1.04 Modular telephone sets are available assembled (less cords) or as components (housing, handset, telephone set base, etc.). See Tables A through D.

1.05 This section provides for the installation of connecting blocks, modular telephone sets, and modular components; conversion and/or repair of nonmodular telephone sets and nonmodular components.

2. IDENTIFICATION

2.01 When installing modular telephone sets or converting sets to modular, various items of the following auxiliary apparatus will be required.

(1) **Connecting Blocks.**

Note: All connecting blocks will accept modular mounting cords, however, the 630A4 is used primarily for wall sets with 523A- or 523B-type plugs.

- 625A—Surface mounted for new installations (includes 42-type terminal block, Fig. 8).

NOTICE

Not for use or disclosure outside the
Bell System except under written agreement

- 625B—Flush-mounted for new installation with associated mounting hardware and coverplate (Fig. 9).
 - 625C—Same as 625A less 42-type terminal block (Fig. 8).
 - 625F and 625FS—Flush-mounted for new installations, or for replacement of existing 47D or 47F connecting blocks and 548A jack (Fig. 10 and 12).
 - 625H—Same as 625FS except provides contacts for two conductors only instead of four conductors (Fig. 12).
 - 625S—Surface-mounted for new installations, (includes 42-type terminal block, Fig. 13).
 - 625T—Same as 625S less 42A terminal block.
 - 635A (MD)—Series connecting block (650A jack, Fig. 18).
 - 635B—Series bridged connecting block (651A jack, optional 652A jack, Fig. 19).
 - 630A—Surface mounted for wall set mounting (accepts 523-type plug and attaches set to wall, Fig. 14).
- (2) **Cover (Fig. 11):** The 158A cover protects the exposed screw terminals of 625F and 47F connecting blocks and 548A jack.
- (3) **Handset Cord Jacks (slip-on).** Used for conversion of telephone bases and telephone set bases (H4DU cord).
- 616B jack for TOUCH-TONE® wall sets and TOUCH-A-MATIC® sets.
 - 616C jack for rotary wall sets.
 - 616D jack for rotary and TOUCH-TONE general purpose desk, single line, 2-line, and multiline (key) set bases.
 - 616E jack for CALL DIRECTOR® sets.
 - 616J for Multibutton Electronic Telephone (MET) sets and TOUCH-A-MATIC (16) repertory dialer.
 - 616JK jack for key telephone sets (jack with 963-type connector on leads).
 - 616T jack for 10/20 button key telephone sets and multibutton wall sets.
 - 616TY jack for TRIMLINE® desk and wall set bases.
- (4) **Handset Jacks for Handset Cord (H4DU).**
- 616W jack for G15A handsets equipped with 840402598 cup assembly and for K1-type handsets.
 - 616WG jack with short leads for G6- and G7BM handsets.
 - 616W3 jack same as 616WG jack less white lead for G6BM and G8BM (current) since 1977.
 - 616Y2 jack for LED version of TRIMLINE handsets.
- (5) **Telephone Set Base Jacks for Mounting Cords (D4BU, D6AL, D6AM, and D6AP).**
- 623D3 jack for rotary and TOUCH-TONE general purpose desk sets, without options (factory supplied in 500DM and 2500DM telephone sets and 500D2M and 2500D2M telephone set bases).
 - 623D4 jack for rotary and TOUCH-TONE general purpose desk sets, with options (used for field conversion).
 - 623D6 jack for rotary and TOUCH-TONE general purpose sets with multiple options.
 - 623D6B jack similar to 623D6 except leads are 11 inches long.
 - 623E4 jack for transaction telephone sets.
 - 623P4 jack for PRINCESS® sets, and DESIGN LINE* sets.

*Trademark AT&TCo

- 623T4 jack for TRIMLINE desk and wall bases.
- 623D6 jack for 2-line general purpose sets and/or sets with options requiring up to 6 conductors.
- 623P6 jack for 2-line PRINCESS sets.
- 623T6 jack for TRIMLINE desk and wall bases with options requiring up to 6 conductors.

(6) **Plug for Wall Sets:**

- 523A3—three conductors
- 523A4—four conductors
- 523A4B—similar to 523A4 except leads are 2-1/2 inches long
- 523B—for 960A01M and 2960A01M repertory dialers. (Converts desk sets to wall sets.)

(7) **Adapters for Plug-in Mounting of Nonmodular and Modular Wall Sets (must be combined with a 523A-type plug).**

- 228A or 228B adapter for 554-, 555-, 556-557-, 558-, and 559-type telephone sets.
- 229A or 229B adapter for 2554-, 2555-, and 2558-type telephone sets.
- 230A or 230B adapter for AC1-type telephone bases.

Note: **A** coded adapters are shipped without screws but **B** coded adapters have screws driven into the adapter.

Note: In modular wall telephone set and telephone set base codes, no distinction is made between apparatus which include adapters and newer apparatus whose basepans do not require adapters. The wiring and function of the two assembled configurations are identical.

(8) **Modular Cords.**

- H4DU (handset cord) available in 6-foot (standard) and 12-foot (long) lengths.
- D4BU-29 (mounting cord) available in 7-foot (standard), 14-foot (long), and 25-foot (extra long) lengths.
- D6AM-29 (mounting cord) available in 7-, 14-, and 25-foot lengths.
- D6AL-87 (MD) or D6AP-87 (mounting cords) are a twisted conductor cords and should be used in lieu of a D6AM if there is a problem of cross-talk between lines. These cords are also available in 7-, 14-, or 25-foot lengths.
- D8AA-87 (mounting cord) available in 7-, 14-, and 25-foot lengths for options requiring a twisted eight conductor cord.
- M4AR-3, test cord, 15-1/2 inches long with a 4-conductor modular plug on one end, and spade tips on the other for testing modular jacks and connecting blocks.

(9) **Adapters:**

- 224A—D4BU or D6AM (as applicable) cord to 541- and 551-type jacks (Fig. 25)
- 225A—D4BU cord to 548- and 549-type jacks (Fig. 26)
- 227B (MD)—H4DU cord to 220A or 2220B hand telephone sets.
- 227C—component of the D-180824 Kit of Parts used for tip party identification in 220AL hand telephone sets
- 227D—H4DU cord to 220A, 220AL (factory installed), or 2220B hand telephone sets
- 231B—H4DU cord to TRIMLINE base
- 248A (MD) and 248B—D4BU cord (pins 2 and 5) to 2012 transformer (Fig. 28, 29, and 30)
- 267A—for connecting two 4-conductor modular cords to a modular connecting block (Fig. 31)

- 281A—for connecting two 4-conductor modular cords to a modular PRINCESS telephone mounting cord jack
- 282A—component of the D-180825 Kit of Parts used for tip party identification in 220C and 2220C hand telephone sets
- 304A—for connecting two modular cords, one 4- or 6-conductor and one 8-conductor to a modular connecting block
- 153AM1—male miniature ribbon connector for modular cord to 25 pair cable connector, with 6-conductor modular jack (Fig. 33)
- 153AM2—similar to 153AM1 except equipped with 4-conductor jack
- 153BM1—female miniature ribbon connector for modular cord to 25 pair cable connector, with 6-conductor modular jack, (Fig. 33)
- 153BM2—similar to 153BM1 except equipped with 4-conductor jack.

(10) **Converter.**

- 1A converter—permanently converts 548- and 549-type jacks to accept D4BU mounting cord.

(11) **Apparatus Blanks (Fig. 24).**

- 123A—fills in jack notch in 500D2 and 2500D2 modular housing when using spade-tipped cords.
- 124A—fills in jack notches in 2554B2, 702B2 and 2702B2 modular housings, when using spade-tipped cords.

(12) **Tools.**

- 8762D-630 blade, used with D impact tool for terminating station wire leads on 630A4 connecting block.
- 797A tool, used with 788A1 tool (handle), for terminating station wire leads on 630A4 connecting block (Fig. 21).
- 798A tool for notching nonmodular housings to retain slip-on jacks (Fig. 22).

- 799A tool (Fig. 23), a template used to determine notching location on housings.

(13) There are adhesive protective labels available to place over the jack opening of unused connecting blocks. The 841011802 labels are used on 625A or 625C blocks and the 841011810 labels on 625B or 625F blocks.

2.02 Refer to Tables A through D for ordering information.

3. **INSTALLATION**

A. **Connecting Blocks**

3.01 Connections to both 625- and 630-type connecting blocks are made according to Table E to insure compatibility of service. Wiring changes for party line service are made within the set and not at the connecting block.

3.02 The 625-type connecting block provides a termination for station wire and the mounting cord as follows.

- (a) The 625A is intended for new installations of modular desk sets using a surface mounted connecting block.
- (b) The 625C used to convert existing 42A connecting blocks to accept plug-ended mounting cords. Dress leads as shown in Fig. 8.
- (c) The 625F (Fig. 10) is intended for new installations requiring flush-type connecting block or replacement of 548A jack. Install in same manner as 548A jack (Sections 461-610-100 and 461-630-100).
- (d) The 625B assembly (Fig. 9) includes 625F connecting block, 43B bracket, faceplate, and six screws.



The plug entrances of the 625A and/or 625C connecting blocks should be positioned facing downward if at all possible (maintaining sufficient clearance so modular cord can be plugged into jack) or to the right or left, never facing upward. This prevents foreign matter and cleaning fluids from entering the jack (Fig. 8). If notch is required

in cover of 625A or 625C to provide entrance for station wiring, break out appropriate notch using long nose pliers.

(e) The 625S (Fig. 13) and 625FS and 625H (Fig. 12) have a customer operable spring-loaded cover which protects the interior telephone line contact springs from contamination. These connecting blocks are intended for use in areas subject to high humidity and condensation or locations exposed to dripping, washing, mopping, or foreign matter. The 625FS connecting block is intended for use in locations subjected to spray painting. The 625S contains a 42-type terminal block.

(f) The 625T has a spring-loaded cover like the 625S and is used to convert existing 42A or 625A connecting blocks.

3.03 The 630A4 connecting block (Fig. 14), includes a 1034A mounting plate, two 800413577 (P-41357) 3/16-inch screws, two 840705008 5/16-inch screws, and two 803355825 (P-335582) 3/4-inch screws. The 3/4-inch screws are used to attach the connecting block to a box or bracket and either the 3/16- or 5/16-inch screws are used to attach the 1034A mounting plate. The 630A4 connecting block replaces the 630A6 connecting block. The connecting block is intended to mount directly to the wall surface (surface mounted) and various brackets as follows.

(1) To mount the connecting block, use the fasteners indicated in Table H. In all cases, the connecting block should be flat against the wall. It may be necessary to break off the rest ears on early production models to achieve this. If a previous installation used a KS-19407 or KS-20502 bracket, remove it and install the connecting block over opening.

(2) Plumb connecting block. Tighten screws. In some cases, such as when mounting hardware is underflush, the connecting block will distort if screws are too tight. In such cases tighten screws until just tight enough to make the assembly tight on the wall once mounting plate is attached.



The 630A4 connecting block does not recess into wall and may be used with exposed as well as concealed station wire. Exposed wire should enter from the bottom.

Note: Wire that is larger than 22 gauge or which has heavily insulated conductors may cause difficulty in installation and/or damage to the connecting block. Retermination at the same connector slot is unreliable.

(3) The 630A4 connecting blocks manufactured after 3-77 will be shipped from the factory with a plastic protective wrapper folded around the quick-connect terminals. To connect station wire, fold out the front and side flaps, make connections and dress leads per (3)(b), and refold wrapper across terminals. This wrapper protects the terminals from foreign matter and also prevents wire ends from making contact with 1034A mounting plate. If a 630A4 connecting block without this protective wrapper is used, insulating tape should be applied to the inside surface of the 1034A mounting plate to prevent any wire ends from making contact with the plate. Make connections as shown in Table E using the following procedures.

(a) Do not strip conductors, (unless using excessively large conductors).

(b) Dress the conductors in such a way that they will not be crossed over each other and/or pinched.

(c) Insert conductors snugly into bottom of slots with the lead insertion tool (Fig. 17). Do not twist or rock the tool, and allow generous slack. Do not insert more than one conductor in each slot.

Note: The blade of this tool (Fig. 21) is plastic and disposable. It should be replaced after 100 to 200 operations or sooner if wear is excessive.

(d) Trim (not on looping terminations) and dress leads as shown in Fig. 17.



Clipped conductor ends shall be bent toward the mounting surface so they will not contact the mounting plate and cause trouble on the line.

Approximately 1/4-inch of wire should be left for bending over.

Note: The connecting block has four quick-connect terminals, each providing three station wire terminations. Holes for test probes are provided on each terminal (Fig. 15).

(4) Attach the mounting plate (Fig. 14). The mounting plate may be easier to install with 5/16-inch screws, but in some cases of surface mounting they protrude into the wall behind the connecting block when fully tightened. When they cannot be completely tightened due to interference with the wall, the 3/16-inch screws should be used.

(5) Check for continuity on each lead by inserting M4AR-3 cord and connecting hand test set.

3.04 A 635A (MD) connecting block (Fig. 18) may be used for series type service or when exclusion is provided. The 635A connecting block is designed to be used with an 8-conductor modular cord. Connections for the 635A connecting block are shown in Table F.

3.05 The 635B connecting block (Fig. 19) replaces the 635A connecting block and is used to permit company-owned and customer-provided equipment using the D8AA mounting cord to be placed in series with telephone company equipment. A 652A jack may be field-installed on the 635B connecting block to provide plug-in capability for additional equipment.

3.06 The 74D connecting block contains a 6-conductor modular jack and was designed for use with the two-line PRINCESS telephone sets. It may also be used for mounting ringer isolators or other ringer coupling devices used with modular type telephone sets when the devices can not be mounted within the sets or whenever five or six conductors are required. Internal connections for the 74D connecting block are shown in Table G.

B. Backboards

3.07 A 191-type backboard (Fig. 20) may be installed by snapping over the 630A4 connecting block. Its use in this manner is optional, for decor purposes. The 191C backboard incorporates the features of the 182B and 191B backboards.

All holes have knockouts that conceal the holes not being used. Also the code numbers of the sets used with this backboard are molded into the back adjacent to the appropriate holes for each set.

The 191C backboard is available in colors per Table A.

C. Telephone Sets

3.08 Install assembled modular telephone sets and bases as follows.

(1) Install appropriate connecting block for a desk (paragraph 3.02) or wall (paragraph 3.03) set.

(2) Plug handset and mounting cords (desk sets) into the handset and telephone set base.

(3) For desk sets, plug mounting cord into connecting block and test for proper operation.

(4) When connecting set to wall, proceed as follows to prevent damage to 523-type plug or to receptacle in 630A-type connecting block.

(a) Begin with slight engagement of plug in receptacle.

(b) Raise set (with plug slightly engaged) and push toward wall to engage studs in corresponding holes in base of set. (The plug will slide up and down in the base of the set.)

(c) **Pull set downward until firmly seated.**

(d) Gently tug on the top and then on the bottom of the set. If one of the studs is not engaged, that end of the set will move away from the wall. In that case, push up to remove the set and repeat the procedure.

(e) Test set for proper operation

(5) Provide modular station number card E-6417 for rotary set and E-6418 for TOUCH-TONE sets (letter M is located above the area code).

3.09 Install and assemble modular telephone sets and components as follows.

- (1) When assembling the following sets, make any required wiring changes (see Part 4) before installing housing.
- (2) Install appropriate connecting block if required.
- (3) On 500D2M and 554B2P (Fig. 36), install dial parts as required for dial being used.
- (4) Install housing (including faceplate for 2500D2 housing).
- (5) Mount set (wall sets only) on 630A4 connecting block [paragraph 3.07(4) or Fig. 34].
- (6) Install handset, handset cord, and mounting cord (desk set only) as shown in Fig. 1 through 7.

Note: When installing H4DU handset cord on some TRIMLINE telephone bases, it is necessary to use 231B (base) and 227D (hand telephone set) adapters.

- (7) Test for proper operation.
- (8) Provide modular station number card.

D. Special Purpose Handsets

3.10 Where required, the G15A handset used with these sets can be replaced with other types.

- G4BM—shoulder rest
- G6BM or modified G8BM—impaired hearing
- G7BM—weak speech
- G8BM—noisy locations.

Refer to Section 501-210-102 for additional information on the G4BM and Section 502-211-102 for additional information on the G6BM, G7BM, and G8BM handsets.

3.11 Special purpose transmitters for use with G15A handset are the KS-16664L3 (high noise level) and KS-20043L2 (low noise level). For installations requiring 238-, 276-, or 277-type amplifier, install amplifier on G15A handset transmitter cup to terminals shown for handset leads in Section 501-226-100.



When nonmodular components must be replaced during installation or repair visits, refer to Part 4.

E. Apparatus Blanks

3.12 The 123A and 124A apparatus blanks (Fig. 24) are one-piece slip-on blank which are required whenever a modular plan housing (notched for jacks) is used with a spade-tipped handset and/or mounting cord.

3.13 The 123A apparatus blank slips on the baseplate flange (Fig. 37) and fills the housing notch for handset cord and/or mounting cord in the 500D2 and 2500D2 housings.

3.14 The 124A apparatus blank has two faces. The higher face is used to fill and conceal the notch in the 2554B2 housing (Fig. 39). The lower face fills and conceals the notches in the PRINCESS set housings. The blank is slipped on the housings so that its unused face is inside the housings and the grooved edges mate with the edges of the housing hole.

F. Adapters

3.15 The 224A and 225A adapters are intended for use when it is not desirable to replace existing jacks. The 227- and 231-type adapters are used with TRIMLINE sets.

- (a) The 224A adapter (Fig. 25) is used to adapt D4BU mounting cord to the 541A and 551A jacks (12 pin jack).
- (b) The 225A adapter (Fig. 26) is used to adapt D4BU mounting cord to 404B (MD), 493A (MD), 497A (MD), 548A, and 549A jacks (4 pin).

Note: The 541A, 548A, 549A, and 551A jacks should not be mixed with 625-type connecting blocks where portable telephone service is required.

- (c) The 227A (MD), 227B (MD), and 227D adapters (Fig. 4) are used to adapt H4DU handset cord to 220A, 220AL (factory installed), or 2220B hand telephone set. The 227D adapter replaces the 227B adapter.

(d) The 227C adapter is similar to the 227D except it is used for tip party identification in 220AL hand telephone set only. The 227C, component of the D-180824 Kit of Parts, has black and yellow spade-tipped leads for connection to the network.

(e) The 231A (MD) or 231B adapter (Fig. 4) is used to adapt H4DU handset cord to AD2M or AC1M bases.

3.16 The 248A (MD) adapter will connect to a dial light transformer (Fig. 30) and has a jack that accepts one end of a modular mounting cord. The other end of the cord would plug into a 281-type adapter to provide power for dial/night lights. Power is provided on pins 2 and 5 of the 248A adapters. The 248A is also used with a 2012B transformer to provide power to 16-button TOUCH-A-MATIC telephone sets.

Danger: When providing power for illuminated station sets, two or more transformers should never feed the same inside wiring pair. If one transformer is unplugged while the secondary terminals of that transformer are being energized through the inside wiring, by another transformer, the exposed terminal blades of the unplugged transformer would be energized with approximately 110 volts ac. Installations of multiple transformers connected to the same inside wire pair should be avoided and corrected if encountered in the field.

3.17 The 248B adapter (Fig. 29) is similar to 248A adapter (Fig. 28) except it will mount on transformers with different center spacing between screw terminals. The 248B is available in two colors Lt. Olive Gray (-49) and Ivory (-50).

3.18 The 267A adapter (Fig. 31) is a modular TEE adapter with two 6-conductor modular jacks designed to plug into a modular connecting block and will accept D4BU, D6AM, D6AL, or D6AP modular cords. A wiring schematic is shown in Fig. 32 for the 267-type adapter and outlines some of the applications in which it may be used.

Caution: Because of the possibility of installing more than one transformer on the same inside wiring pair, the 267A

adapter shall not be used to connect dial light transformers to modular systems.

3.19 The 281A adapter is a modular TEE adapter with one 4-conductor modular jack and one 2-conductor modular jack. It provides connection of mounting and dial light cords to modular PRINCESS telephone sets.

3.20 The 282A adapter, when installed on the existing handset cord jack of the 220C and 2220C hand telephone sets, provides two additional leads for connection to the network when tip party identification is required. The 282A adapter is a component of the D-180825 Kit of Parts.

3.21 The 304A adapter is a modular TEE adapter with two modular jacks designed to plug into a modular connecting block. One modular jack (PHONE) will accept D4BU, D6AL, D6AM, or D6AP modular cords and the other jack will accept D8AA modular cord.

3.22 The 153AM1 and 153BM1 adapters (Fig. 33) are miniature ribbon connectors for connecting one line to a 25 pair cable connector or bridging point. The 153AM1 is a male connector and the 153BM1 is a female connector. Both adapters pick up pin terminals 1-26, 2-27, and 25-50 in a 25 pair connector and may be used to connect a single line set to key system cable. Wiring is available in these adapters to allow modification to pick up pins 4-29, 5-30, and 20-45 in a 25 pair connector.

3.23 The 153AM2 and 153BM2 adapters are equipped with a 4 pin modular jack and will pick up pin terminals 1-26 and 2-27 in a 25 pair connector.

G. Converter

3.24 The 1A converter is permanently installed to permit the D4BU mounting cord to be used with 548A- or 549A-type jack. The converter cannot be removed once it is installed.

4. CONVERSION

4.01 Convert telephone set as follows.

- (1) Remove housing, handset, and spade-tipped handset cord. If wall set, disconnect inside wire. If desk set, remove spade-tipped mounting cord.

Note: If a current version of the G3 handset is being used (modular type cord opening in handset), it may be converted to a G15 handset per Section 501-210-103.

- (2) On rotary dial sets requiring housing color change, remove fingerwheel, finger stop, and dial number plate.
- (3) On 7-type dials, remove the protrusion of the finger stop support (part of the dial frame) in such a manner that the remaining stop surface shall not project above the lip of the frame. Install the universal number plate, using the 840699979 lock ring and two 802108100 RHM screws, and the 840161285 finger stop. Provide modular station number card and install fingerwheel.
- (4) For sets equipped with 9C-type dial, install universal number plate, finger stop, and 811152974 (P-11E297) lock ring. For sets equipped with a 9CA-type dial, install universal number plate and 840158372 finger stop—lock ring not required. Install 811714229 (P-17A422) ring assembly over edge of number plate. Provide modular station number card and install fingerwheel.
- (5) For wall telephone set, inspect basepan of telephone set. If there is an opening for a 523A plug, install as follows.
 - (a) The end of the plug marked "TOP" shall be oriented toward the top of the basepan. One side of the plug should be engaged in the track first. Then the plug should be rolled in toward the pan to snap in the opposite side.
- (6) If basepan of wall set does not have the previous feature, install and connect the correct adapter (228, 229, or 230) and the 523A-type plug (Fig. 27). Install appropriate handset cord jack per Table B or C.
- (7) For desk telephone sets, modify basepan of telephone set base where required and install handset and/or mounting cord jacks per Fig. 41 through 50.
- (8) Connect plug and/or jack leads per specific telephone set practices. Insulate and store unused conductors. Dress all leads to avoid ringer gongs, moving parts of ringer and line switch, and interference with other components when set is assembled.
- (9) On sets requiring no housing change, install notched housing. If a notched housing is not available, punch housing per Fig. 51, 52, and 53 except for AC- and AD-type telephone bases which require no housing modification.
- (10) Mount the wall telephone set base on the 630A4 connecting block (Fig. 34).
- (11) Install handset, handset cord, and (desk set only) mounting cord.
- (12) Provide modular station number card E-6417 and/or E-6418.

5. CONNECTIONS

5.01 Bridged Ringing Standard: All modular telephone sets will be supplied connected for bridged ringing.

5.02 Polarity Guards: Refer to appropriate Reference section in Division 502 for ordering and installation information.

6. MAINTENANCE

6.01 Replaceable Items: Standard replaceable items such as ringers, dials, receiver units, etc. can be replaced or maintained in accordance with sections covering the particular item.



When a 523A-type plug is used with an adapter, dress the plug leads as shown in Fig. 27 to prevent shorting or grounding the leads.

SECTION 503-100-100

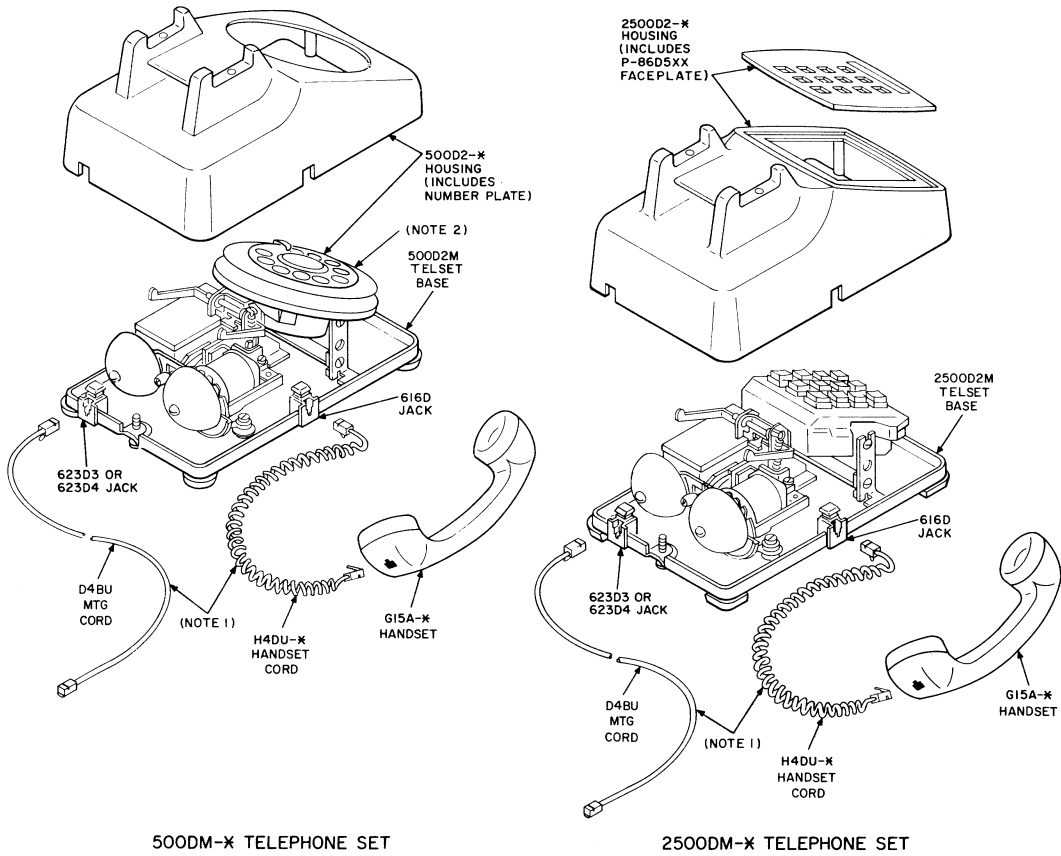

* ADD TWO DIGIT COLOR CODE.

NOTES:

1. CORDS SHOWN ARE NOT INCLUDED WITH TELEPHONE SETS AND MUST BE ORDERED SEPARATELY.
2. DIAL NOT FULLY ASSEMBLED ON SEPARATE TELEPHONE BASES.

Fig. 1—500DM and 2500DM Telephone Sets

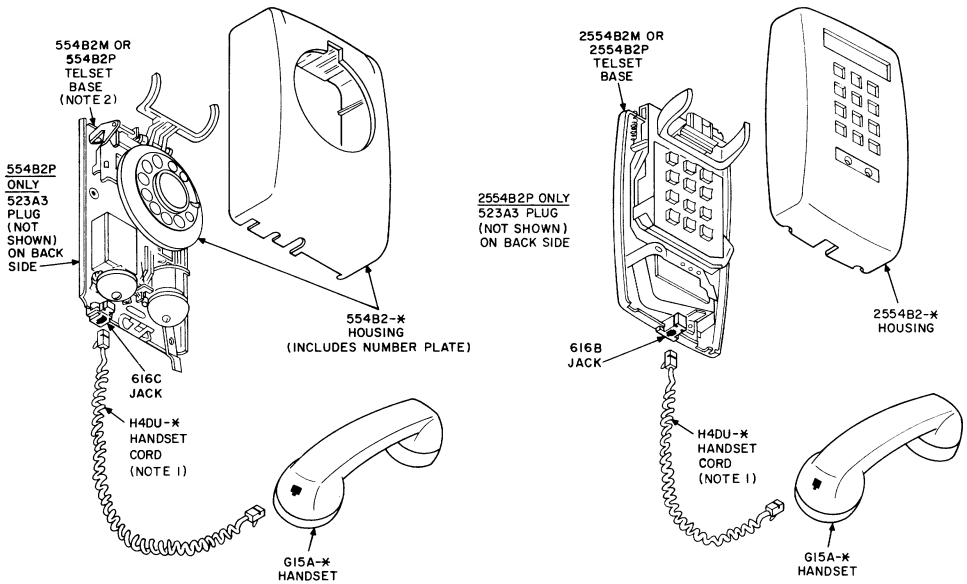

554BM-× AND 554BMP-× TELEPHONE SETS

2554BM-× AND 2554BMP-× TELEPHONE SETS

* ADD TWO DIGIT COLOR CODE.

NOTES:

1. H4DU-× CORDS MUST BE ORDERED SEPARATELY.
2. DIAL NOT FULLY ASSEMBLED ON SEPARATE TELEPHONE BASES

Fig. 2—554BM, 554BMP, 2554BM, and 2554BMP Telephone Sets

SECTION 503-100-100

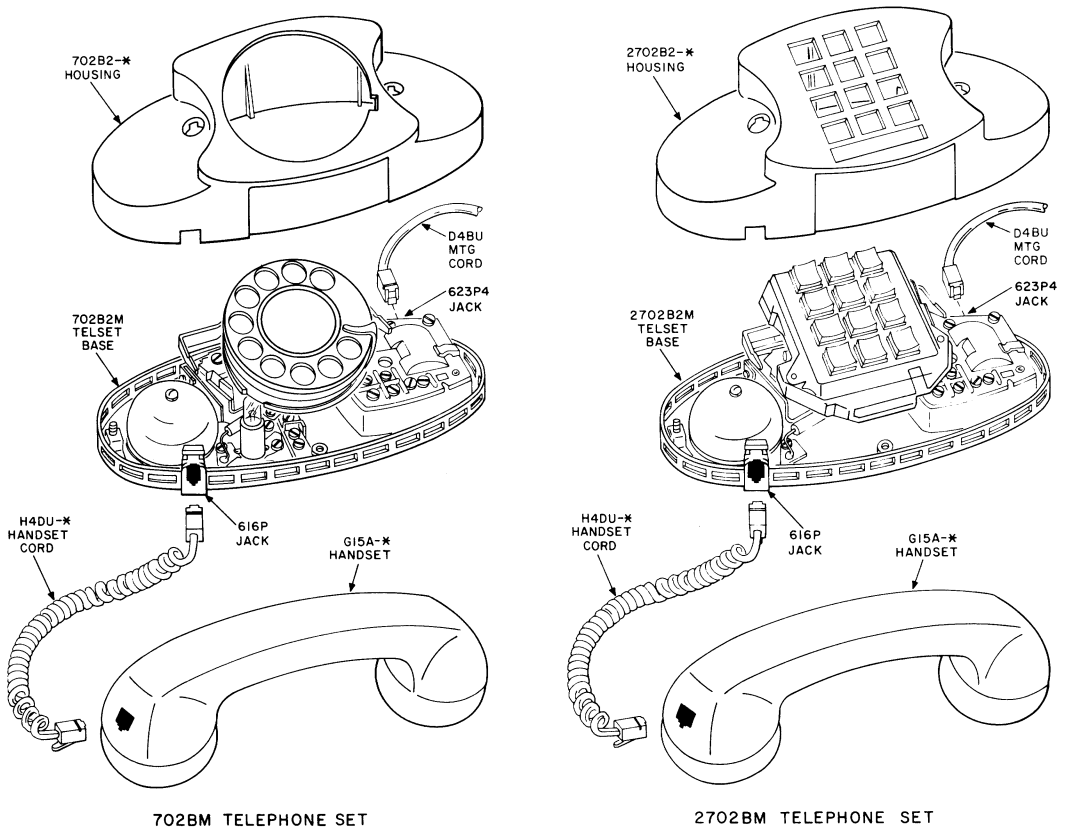

702BM TELEPHONE SET

2702BM TELEPHONE SET

* ADD TWO DIGIT COLOR CODE.

NOTE:

CORDS SHOWN ARE NOT INCLUDED WITH TELEPHONE SETS AND MUST BE ORDERED SEPARATELY.

Fig. 3—702BM and 2702BM Telephone Sets

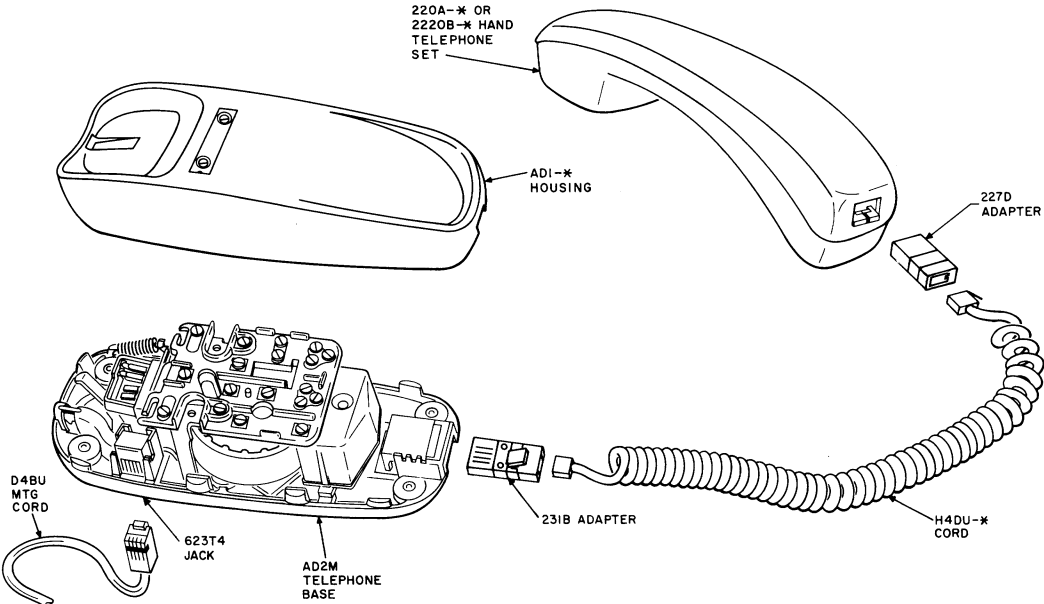

* ADD TWO DIGIT COLOR CODE.

NOTE:
H4DU-* CORD, AND ADAPTERS MUST BE ORDERED SEPARATELY.

Fig. 4—AD2 Telephone Base With 220A or 2220B Hand Telephone Set

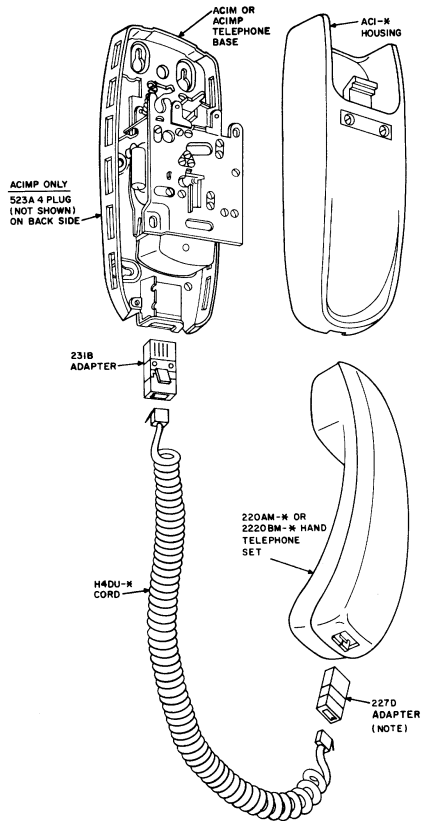

NOTE:

THE 227D ADAPTER IS FIELD OR SERVICE-CENTER INSTALLED IN BOTH HAND TELEPHONE SETS, HOWEVER, 231B ADAPTER AND H40U CORD SHOWN ARE NOT INCLUDED WITH EITHER HAND TELEPHONE SET OR TELEPHONE BASE AND MUST BE ORDERED SEPARATELY.

Fig. 5—AC1 or AC1P Telephone Base With 220AM or 2220BM Hand Telephone Set

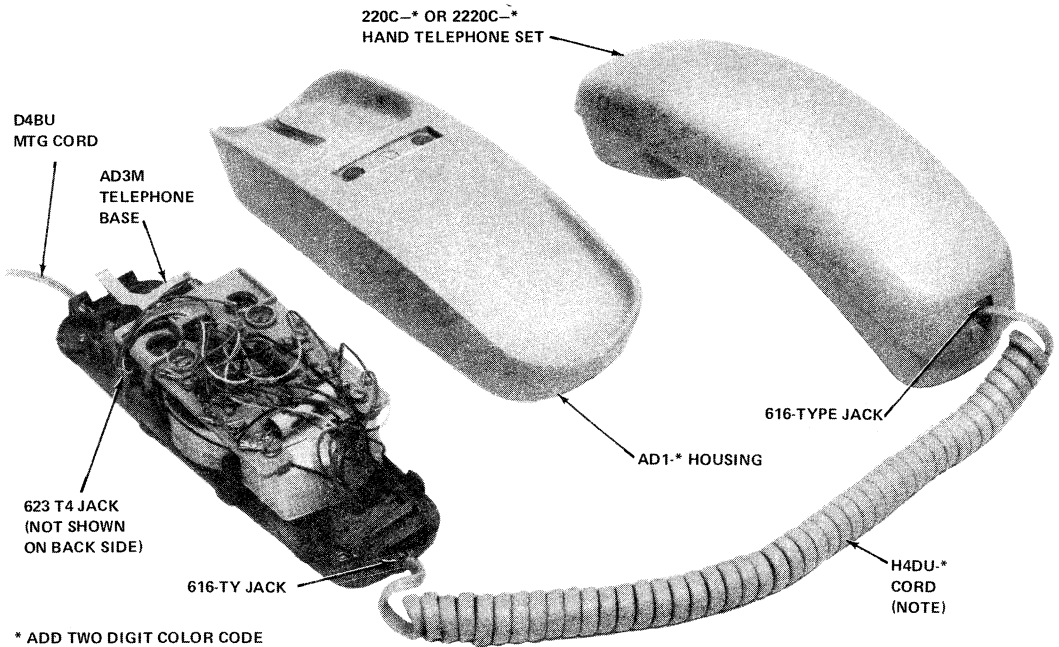

NOTE:

H4DU.* CORD MUST BE ORDERED SEPARATELY.

Fig. 6—AD3 Telephone Base With 220C, 226A, 2220C, or 2226A Hand Telephone Set

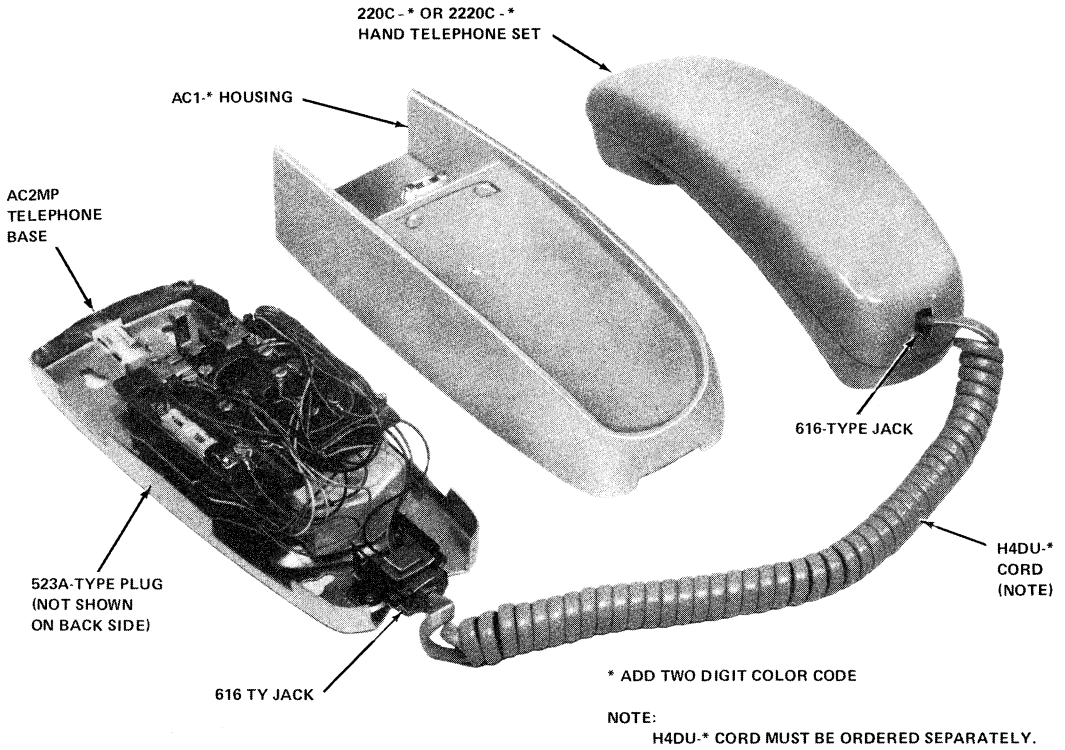

Fig. 7—AC2P Telephone Base With 220C, 226A, 2220C, or 2226A Hand Telephone Set

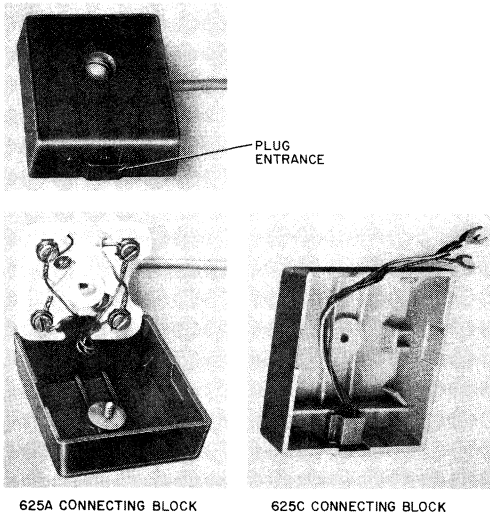
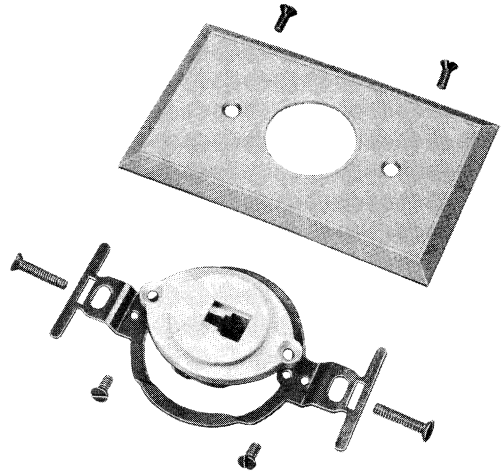
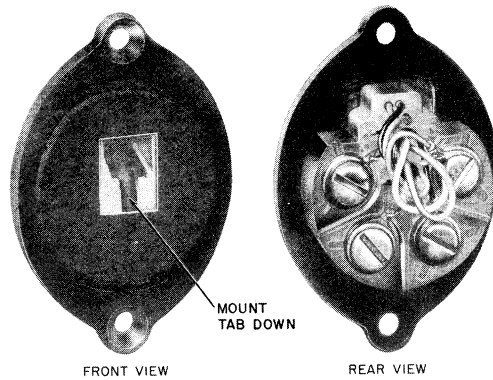

Fig. 8—625A and 625C Modular Connecting Blocks



- 4 CONTACTS
- FLUSH MOUNTED:
FOR USE IN STANDARD ELECTRICAL OUTLET BOX
NOTE:
MOUNTING SCREWS, BRACKET, AND
FACEPLATE PROVIDED
- MATES WITH D4BU MOUNTING CORD PLUG
- FOR NEW INSTALLATIONS OR MODULAR
REPLACEMENT OF 548-TYPE JACKS

Fig. 9—625B Connecting Block Assembly



- 4 CONTACTS
- FLUSH MOUNTED:
USING 63-TYPE OR KS-20502,L2 BRACKET
AND 16A FACEPLATE OR IN STANDARD
ELECTRICAL OUTLET BOX USING 43B
BRACKET OR IN WOODWORK USING
1-1/4 INCH HOLE
- MATES WITH D4BU MOUNTING CORD PLUG,
- MOUNTING SCREWS SUPPLIED
- FOR NEW INSTALLATIONS OR MODULAR
REPLACEMENT OF 548-TYPE JACKS

Fig. 10—625F Connecting Block

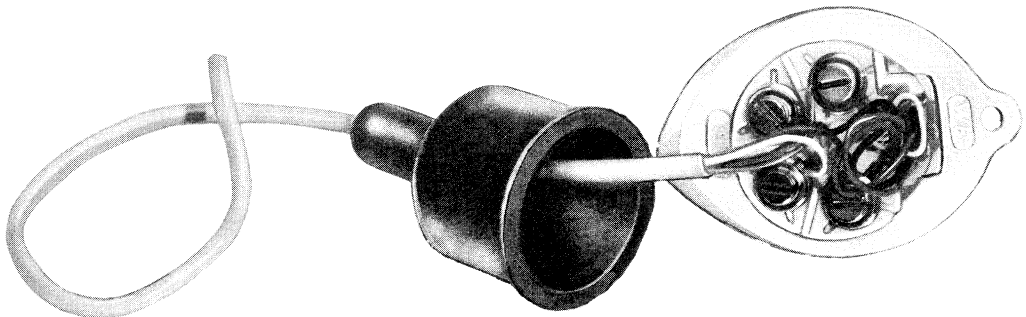
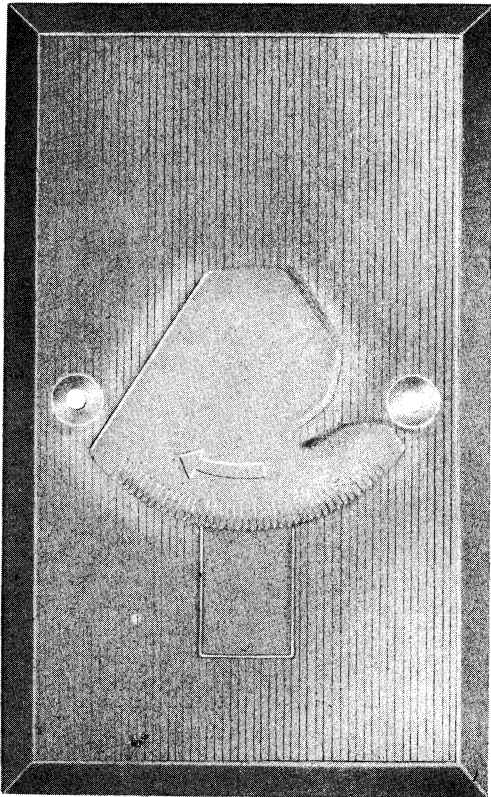
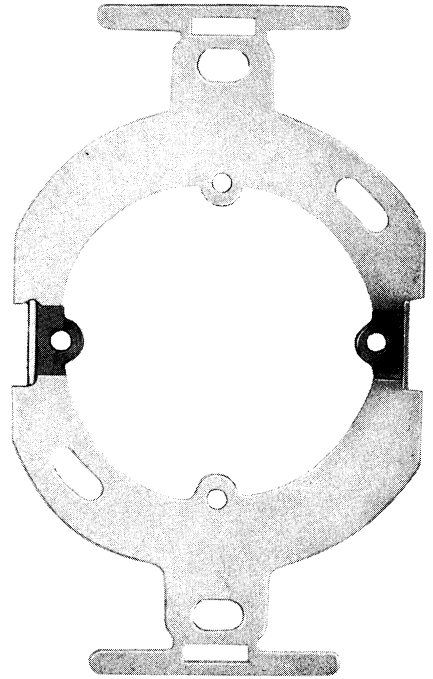

Fig. 11—158A Cover With 625F Connecting Block



BRACKET
(PROVIDED WITH CONNECTING BLOCKS)



NOTE:
BRACKET IS USED TO MOUNT 625FS OR 625H TO GEM
BOX, 63A, OR 63B MOUNTING BRACKET.

Fig. 12—625FS or 625H Connecting Block and Mounting Bracket

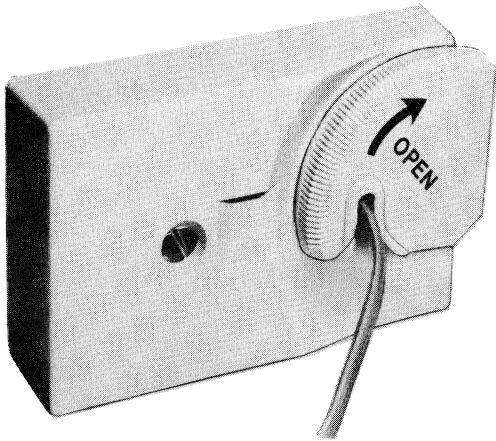

Fig. 13—625S Connecting Block With D4BU Cord Inserted

- (1) 63 - TYPE, KS-20502, L2 OR KS-19407, LI (MD) BRACKET
- (2) GEM BOX AND NORMAL WALL SURFACE
- (3) OR (4) WEAK WALLS, OVER SIZE WIRING HOLE, LOCAL DAMAGE, ETC.
- (5) IO34A MOUNTING PLATE

NOTE:
IF MORE THAN 2 FASTENERS ARE NECESSARY, USE
ADDITIONAL MOUNTING HOLES AS REQUIRED

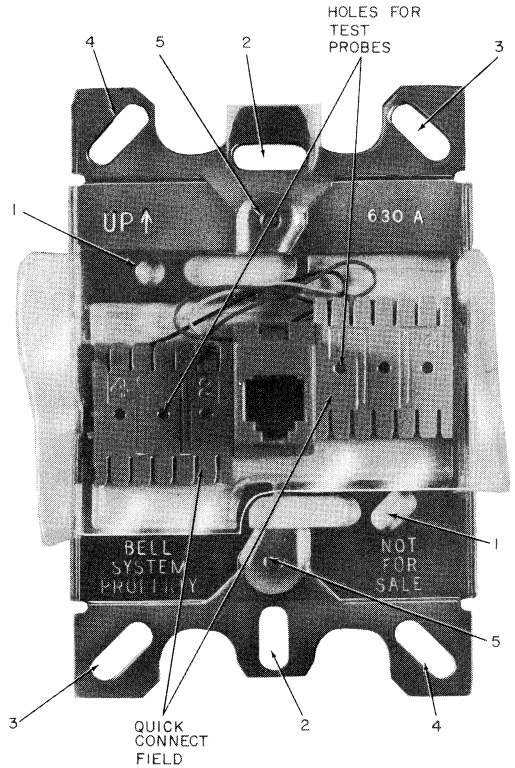

Fig. 15—630A4 Connecting Block With Protective Wrapper (Current Production Model)

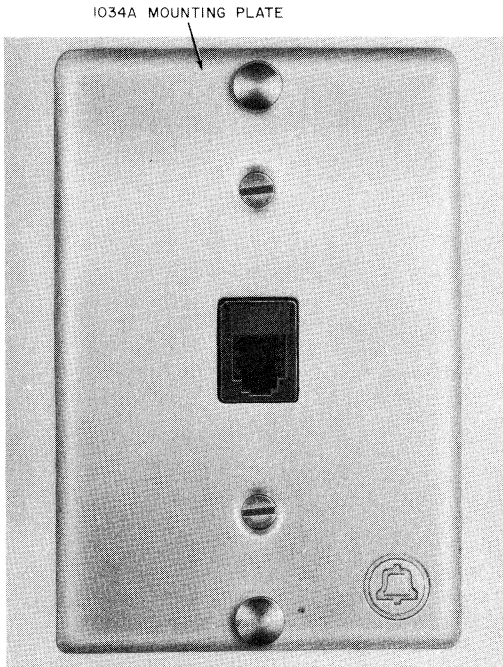

Fig. 14—630A4 Connecting Block

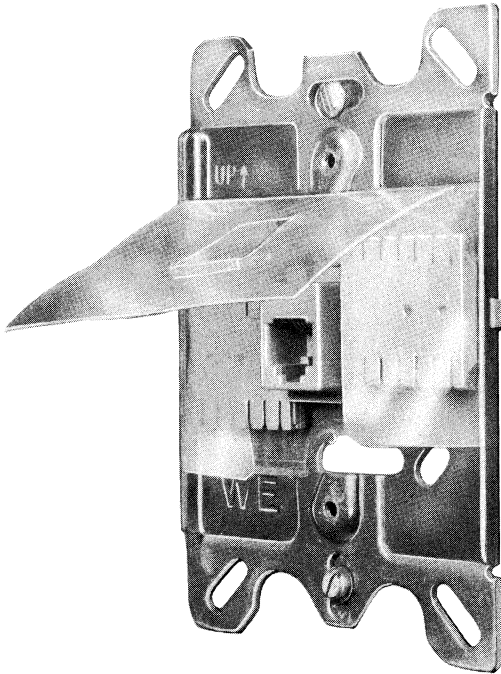

Fig. 16—630A4 Connecting Block - Refer to Fig. 15 for Mounting Instructions

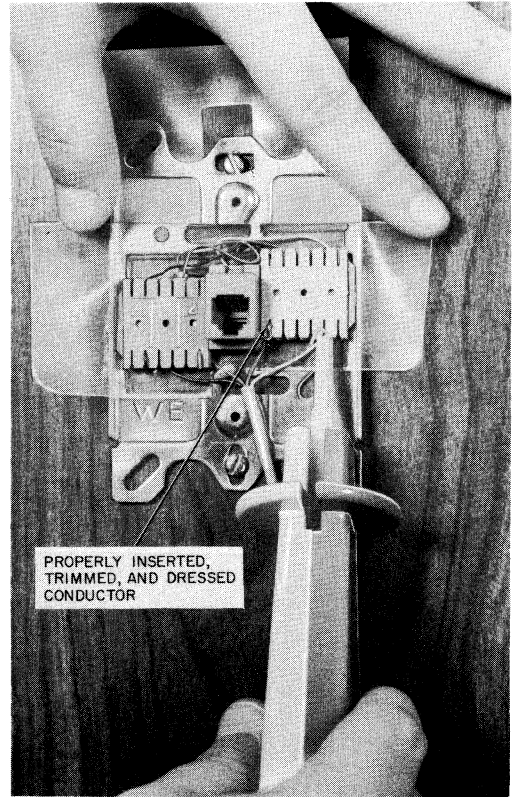

Fig. 17—Connecting Wire With Lead Insertion Tool

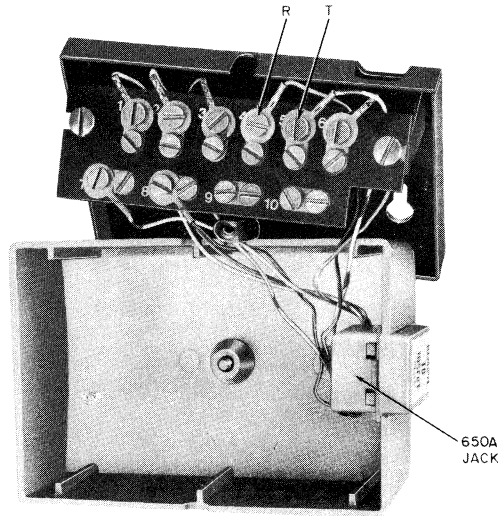

Fig. 18—635A (MD) Connecting Block

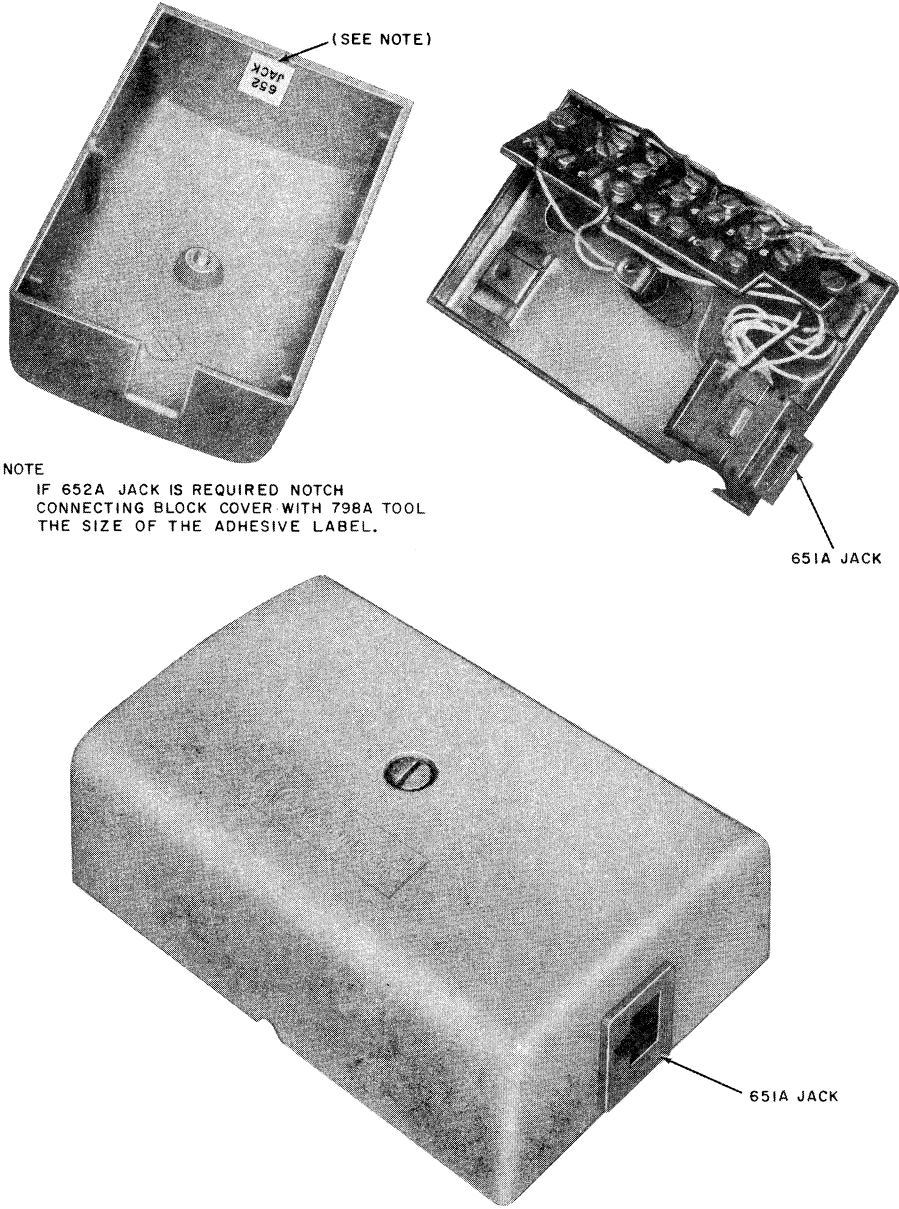

Fig. 19—635B Connecting Block

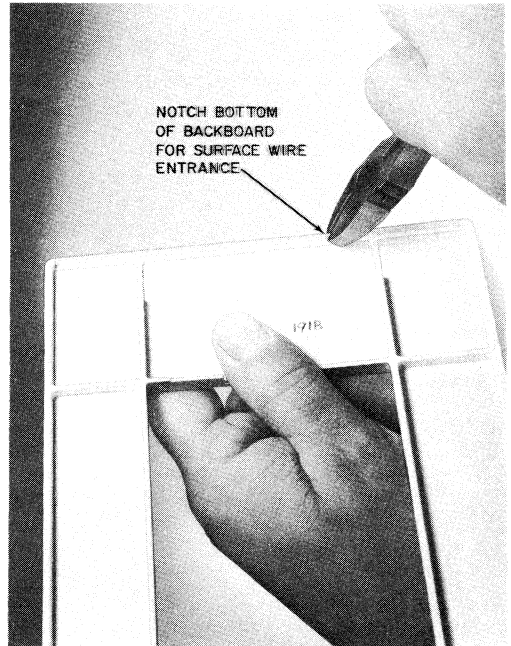
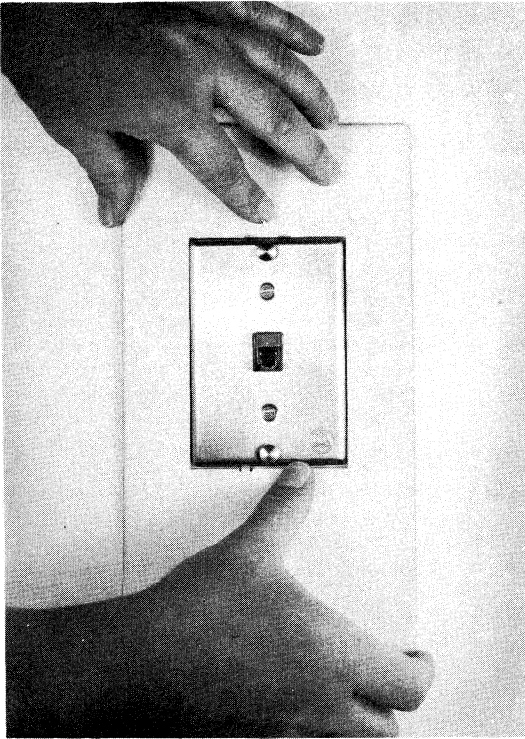

Fig. 20—191-Type Backboard

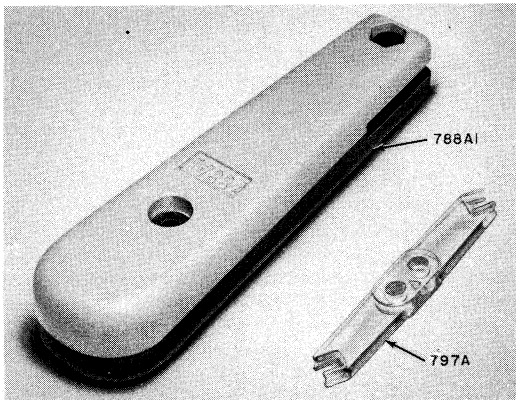

Fig. 21—Lead Insertion Tool

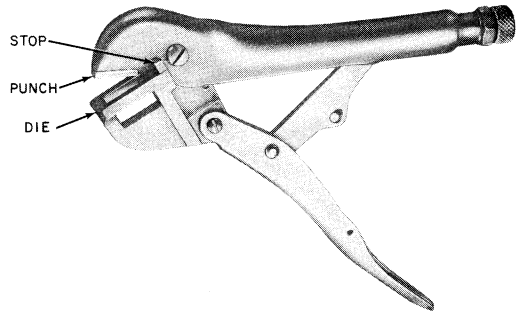

Fig. 22—798A Notching Tool

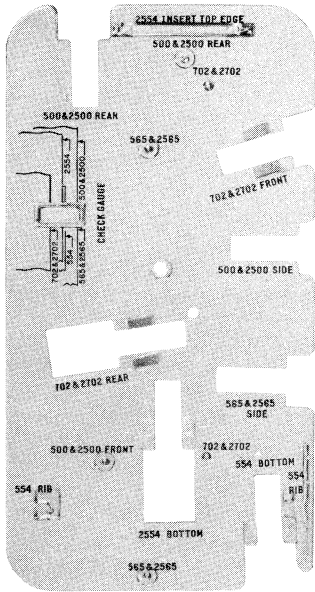

Fig. 23—799A Tool (Template)

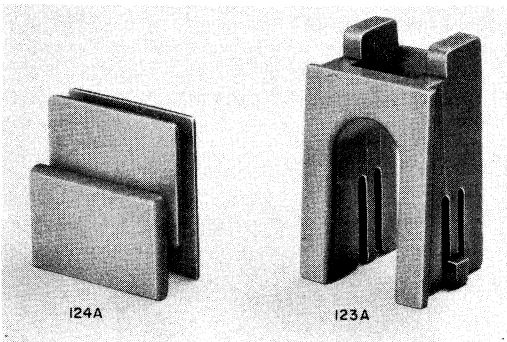

Fig. 24—Apparatus Blanks

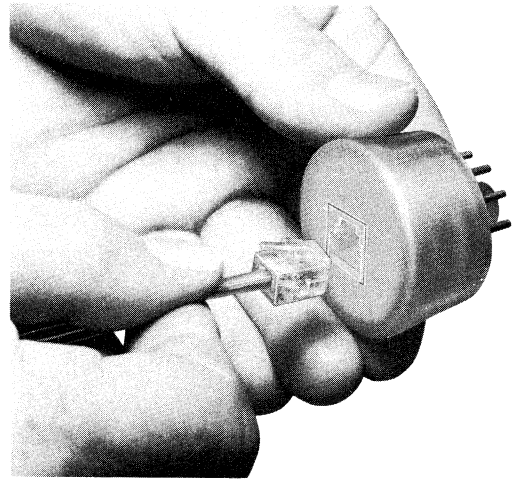

Fig. 25—224A Adapter

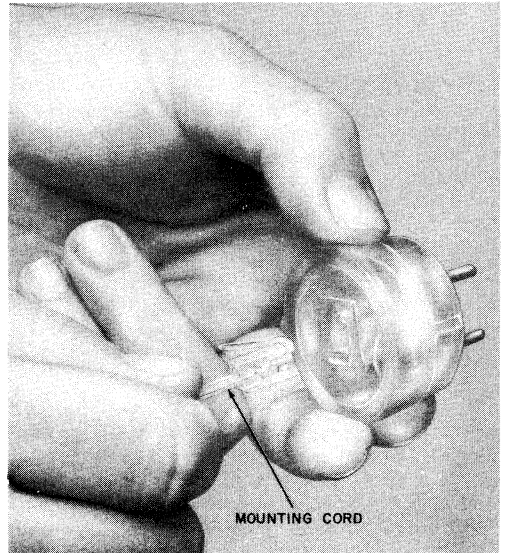

Fig. 26—225A Adapter

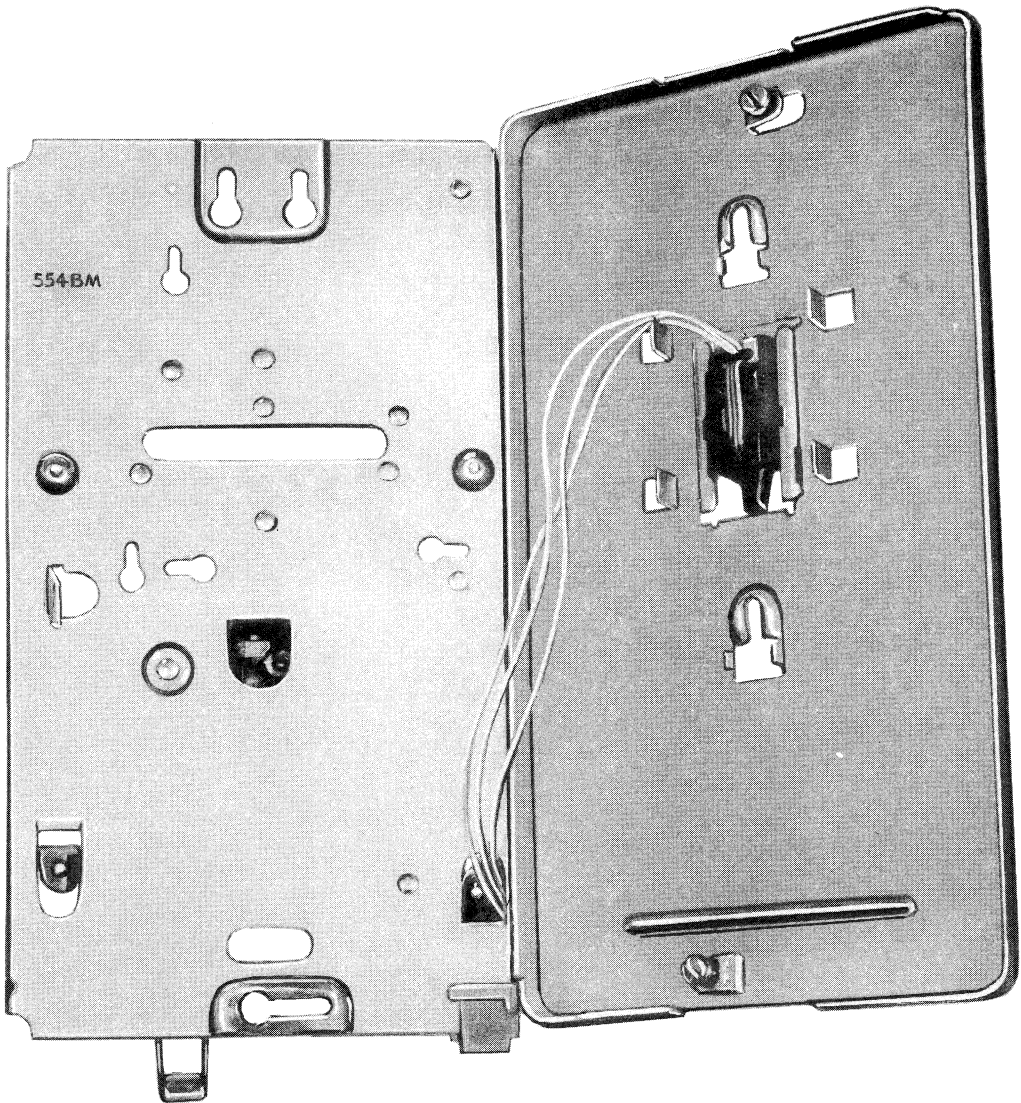

Fig. 27—228B Adapter With 523A-Type Plug, Showing Recommended Lead Routing

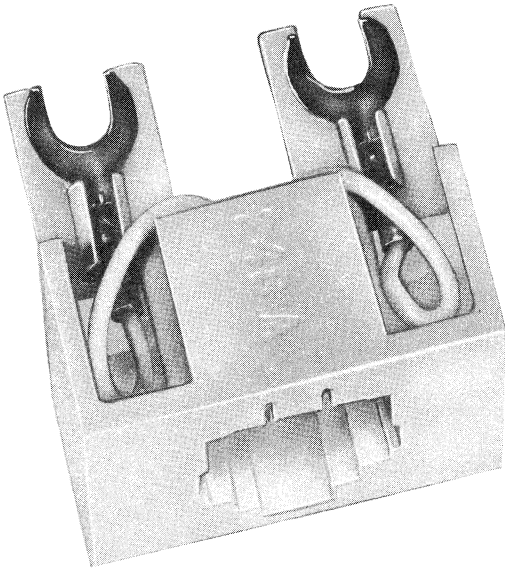

Fig. 28—248A (MD) Adapter

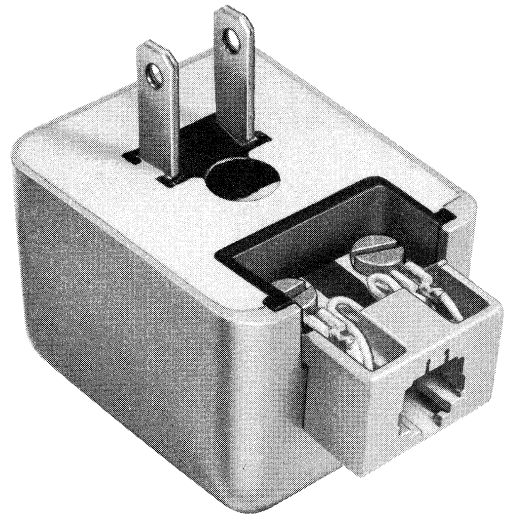

Fig. 30—248A or 248B Adapter as Used With 2012 Transformer

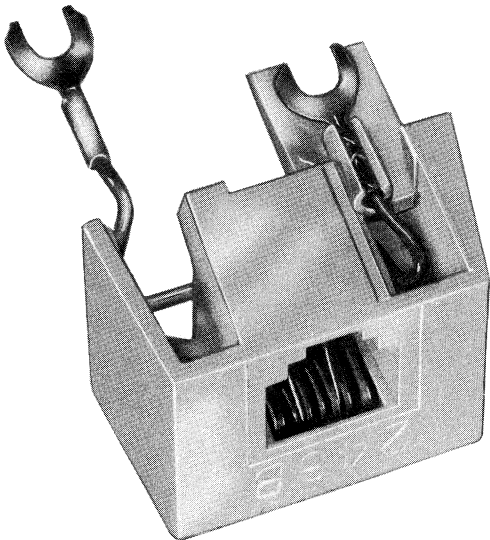

Fig. 29—248B Adapter

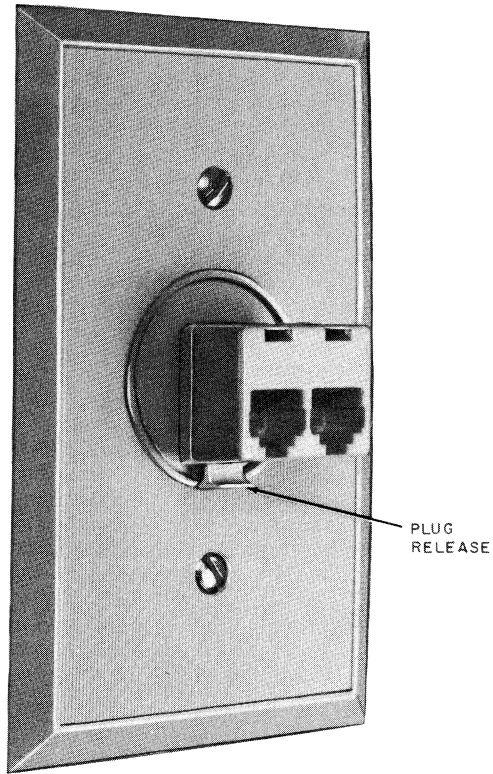

Fig. 31—267A Adapter Plugged into 625B Connecting Block

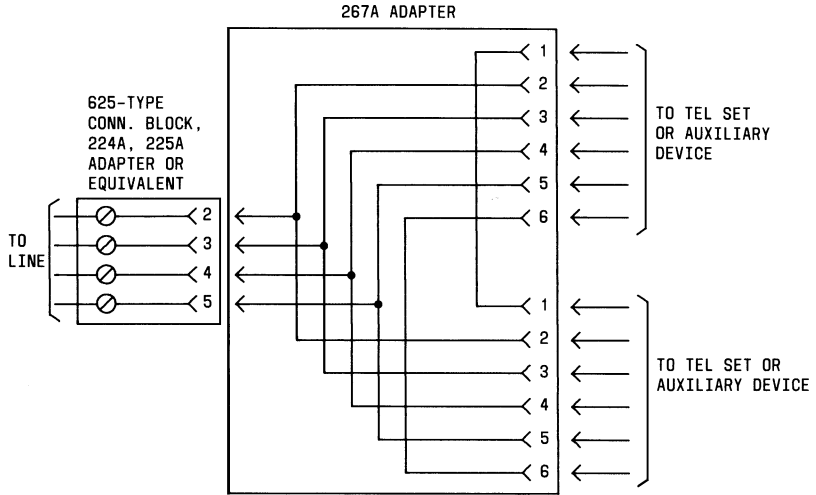

Fig. 32—Schematic of 267A Adapter

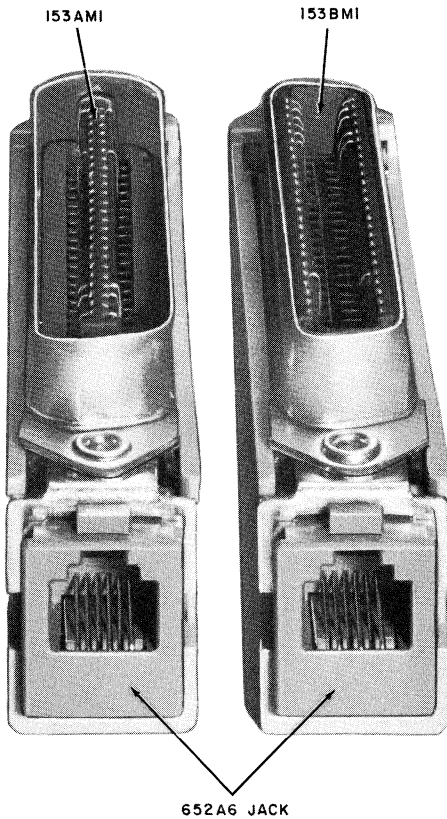
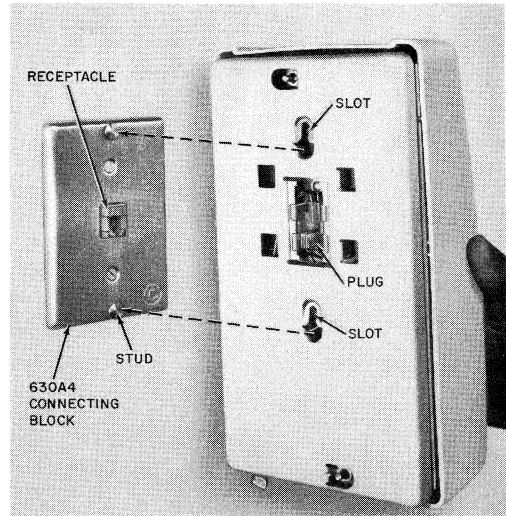

Fig. 33—153AM1 and 153BM1 Adapters



MOUNTING WALL SETS ON 630A4

- (1)—BEGIN WITH SLIGHT ENGAGEMENT OF PLUG IN RECEPTACLE
- (2)—RAISE SET (WITH PLUG SLIGHTLY ENGAGED) AND PUSH TOWARD WALL TO ENGAGE STUDS IN CORRESPONDING SLOTS OF WALL SET ADAPTER OR BASE PAN. (THE PLUG WILL SLIDE UP AND DOWN IN THE BACK OF THE WALL SET).
- (3)—PULL SET DOWNWARD UNTIL FIRMLY SEATED.

Fig. 34—554BMP Telephone Set With 630A-Type Connecting Block



Fig. 35—554BMP Telephone Set on 630A-Type Connecting Block

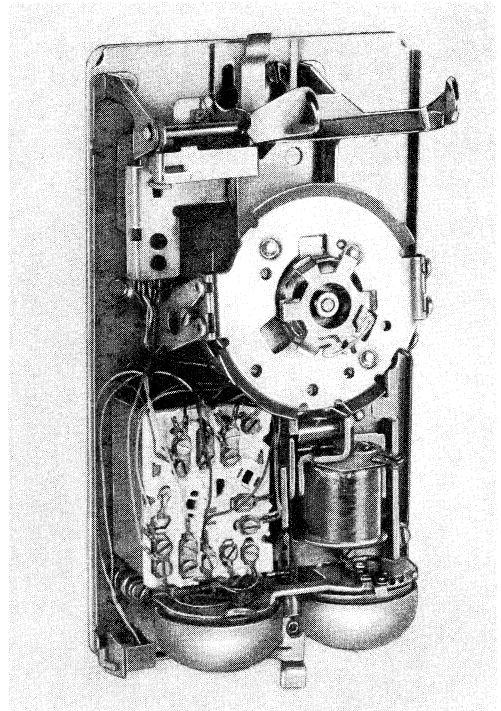

Fig. 36—554B2P Telephone Set Base

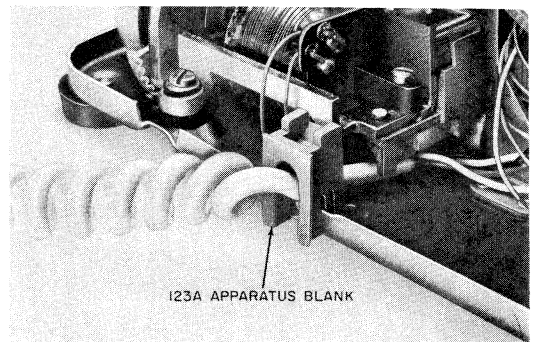

Fig. 37—123A Apparatus Blank Installed on 2500D1M Telephone Set Base

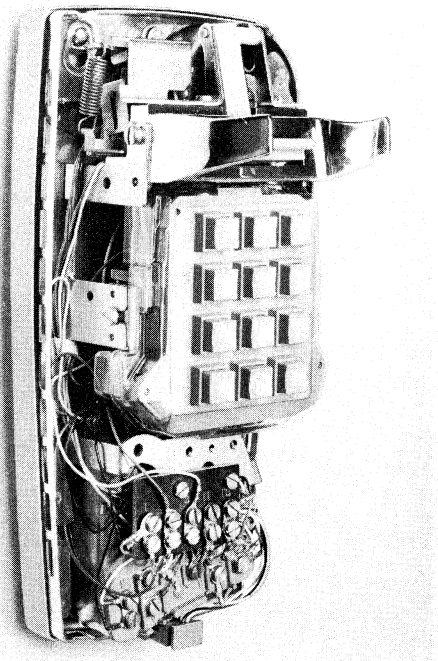

Fig. 38—2554B2P Telephone Set Base

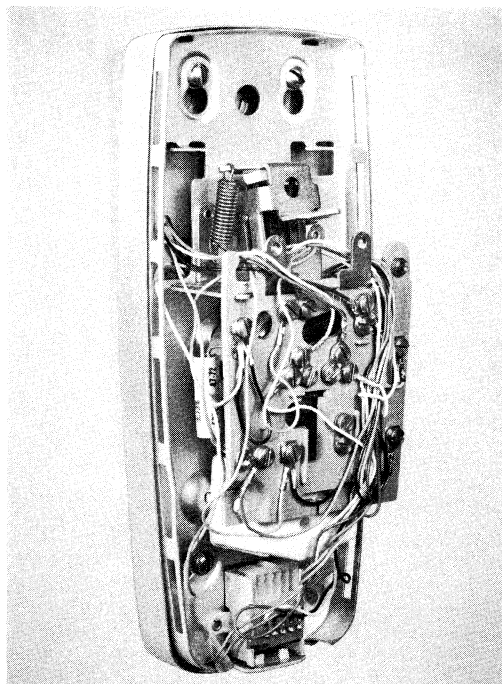

Fig. 40—AC1MP Telephone Base

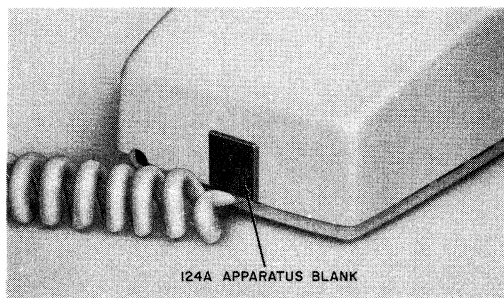

Fig. 39—124A Apparatus Blank Installed on 2554BM Telephone Set

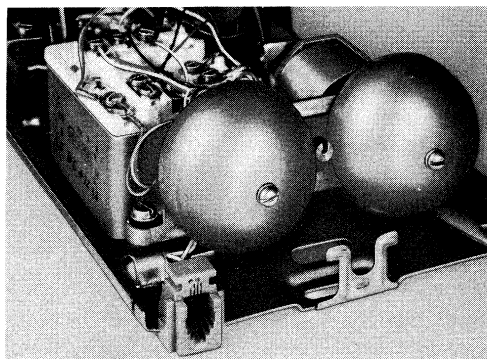

Fig. 41—554B2P Telephone Set Base With Handset Cord Jack Installed

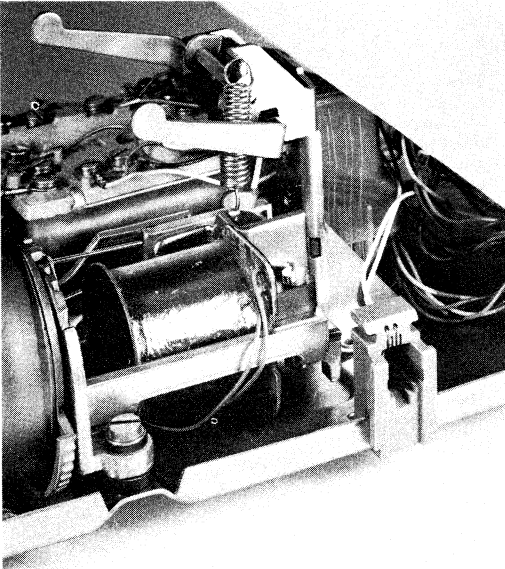

Fig. 42—500D2M or 2500D2M Telephone Set Base With Handset Cord Jack Installed

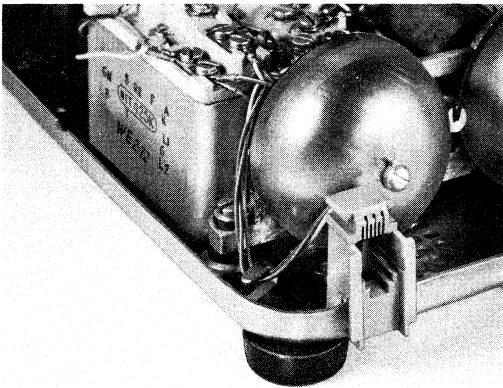

Fig. 43—2500D2M Telephone Set Base With Mounting Cord Jack Installed (500D2M Telephone Set Base is Similar)

NOTE:

ALL PRODUCT MANUFACTURED BEFORE 12-72 REQUIRES THIS MODIFICATION. CHECK FIT OF 623P4 JACK BEFORE REMOVING TAB IN PRODUCT MANUFACTURED BETWEEN 12-72 AND 3-73. PRODUCT MANUFACTURED 4-73 OR AFTER DOES NOT REQUIRE MODIFICATION.

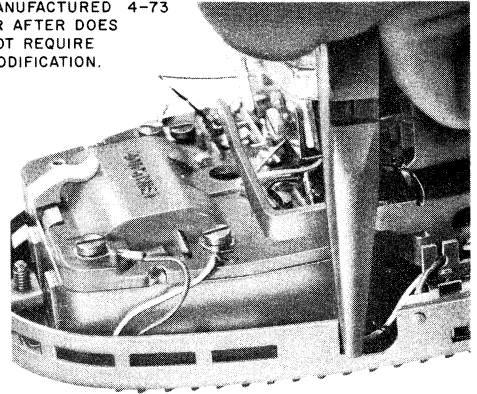

Fig. 44—Modifying PRINCESS Telephone Set Base to Accommodate Mounting Cord Jack

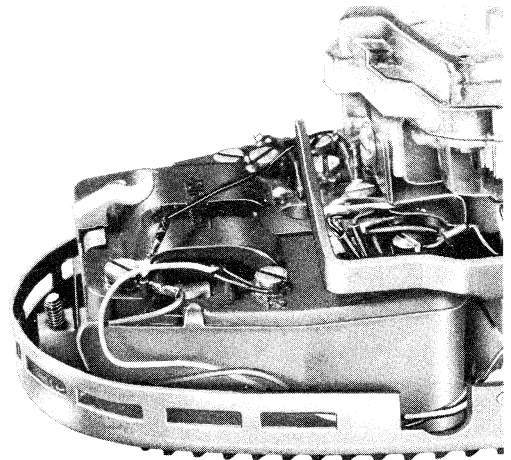

Fig. 45—PRINCESS Telephone Set Base Modified to Accommodate Mounting Cord Jack

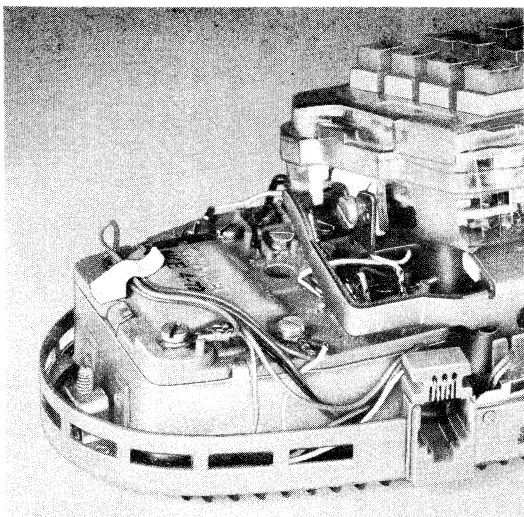
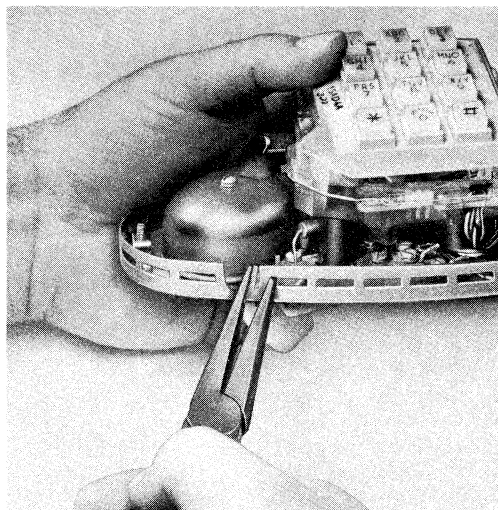

Fig. 46—PRINCESS Telephone Set Base With Mounting Cord Jack Installed



NOTE:

ALL PRODUCT MANUFACTURED BEFORE 12-72 REQUIRES THIS MODIFICATION. CHECK FIT OF 616P JACK BEFORE BENDING TAB IN PRODUCT MANUFACTURED BETWEEN 12-72 AND 3-73. PRODUCT MANUFACTURED 4-73 OR AFTER DOES NOT REQUIRE THIS MODIFICATION.

Fig. 47—Modifying PRINCESS Telephone Set Base to Accommodate Handset Cord Jack

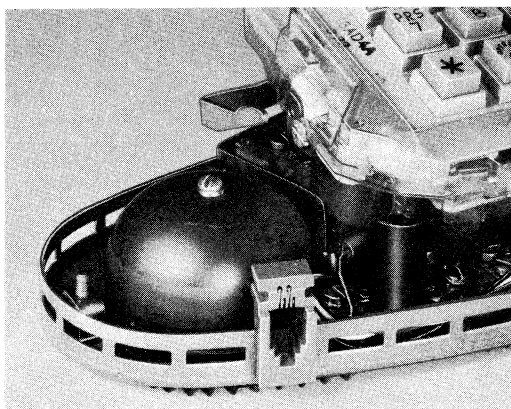

Fig. 48—PRINCESS Telephone Set Base With Handset Cord Jack Installed

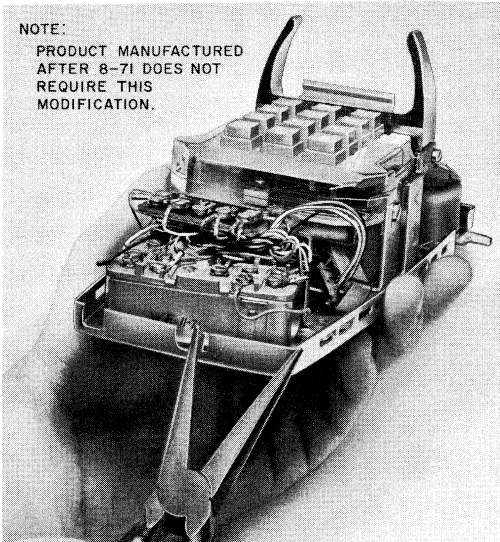

Fig. 49—Modifying 2554B1M Telephone Set Base to Accommodate Handset Cord Jack

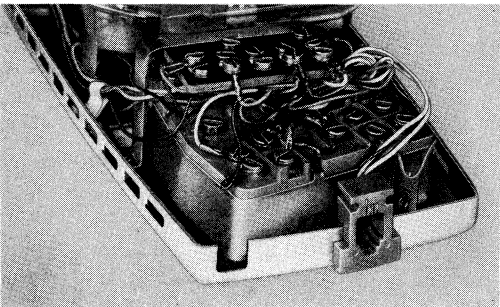
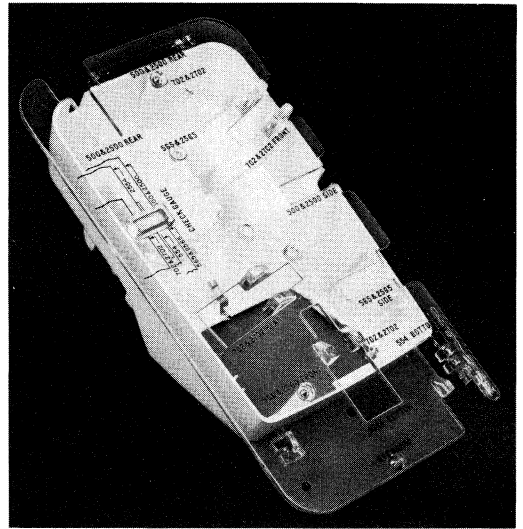

Fig. 50—2554B2M Telephone Set Base With Handset Cord Jack Installed



NOTE:
 ON SOME HOUSINGS IT WILL BE NECESSARY TO REMOVE ANY HOUSING RIBS THAT INTERFERE WITH PUNCHING TOOL. RIBS SHOULD BE CLIPPED OUT WITH DIAGONAL CUT PLIERS. ON THICK HOUSINGS IT MAY BE NECESSARY TO PUNCH HOUSING USING SUCCESSIVE BITES WITH HOUSING PUNCH.

Fig. 51—2500D1 Housing on Template

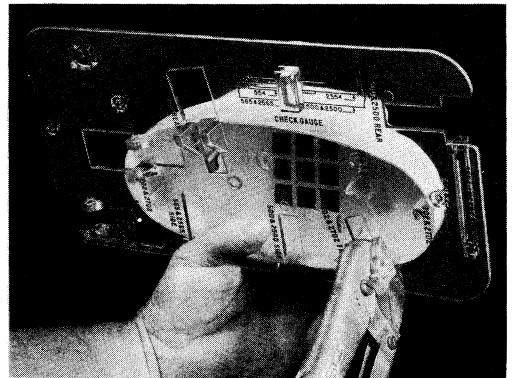

Fig. 52—Positioning Notching Tool (2702B1 Housing on Template)

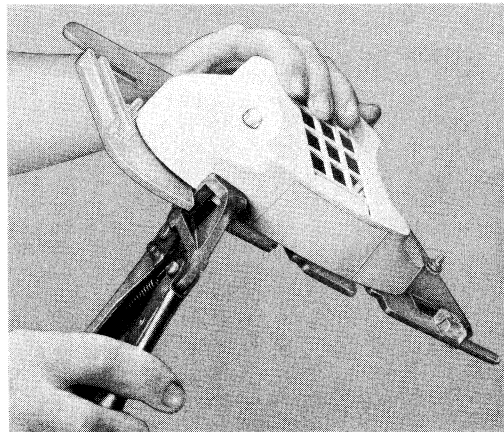
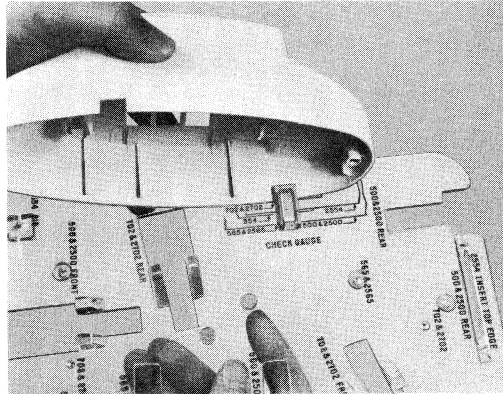

Fig. 53—Notching 2702B1 Housing and Using Check Gauge

TABLE A
COLOR ORDERING GUIDE

TEL SET, HOUSING, 191C BACKBOARD, HANDSET, AND HANDSET CORD (NOTE 2)		COORDINATED FACEPLATE TOUCH-TONE DIAL (NOTE 1)		UNIVERSAL NUMBER PLATE ROTARY DIAL	
Black	-03	Charcoal	-70	840200034	-03
Ivory	-50	Muted Ivory	-80	840200505	-50
Green	-51	Light Green	-71	840200513	-51
Red	-53	Muted Red	-69	840200539	-53
Yellow	-56	Light Yellow	-72	840200562	-56
White	-58	Light Gray	-73	840200588	-58
Beige	-60	Muted Beige	-75	840200604	-60
Aqua Blue	-62	Muted Blue	-76	840200620	-62

Note: 1. Faceplates same color as housing are MD.

Note: 2. TRIMLINE telephone set and associated handset cord, and 191C backboard is available in two additional colors, brown (-104) and Rust (-124).

TABLE B
MODULAR AND PARTIALLY MODULAR TELEPHONE SETS

TELEPHONE SET††	TELEPHONE SET COMPONENTS			CORDS		TELEPHONE SET BASE FEATURES					
	HOUSING†	HANDSET†	TEL SET BASE	HANDSET† CORD	MTG CORD	PLUG	MTG CORD JACK	HANDSET CORD JACK	RINGER	NET.	DIAL
500DM	500D2§		500D2M		D4BU		623D3¶	616D	C4A	425E or 4228A	7-type or 9-type**
2500DM	2500D2		2500D2M							425K or 4228B	35A3A 35Y3A 35Y3D
554BM (MD) ‡	554B2§		554B2M§					616C	523A3††	425E or 4228A	7-type or 9-type**
554BMP	554B2§		554B2P							425E or 4228A	
2554BM (MD)‡	2554B2	G15A	2554B2M§	H14DU				616B	P1A	4010D or 4228K	35A3A 35Y3A 35Y3D
2554BMP	2554B2		2554B2P				523A3††				
702BM	702B2		702B2M						4010B or 4228F	8A	
2702BM	2702B2		2702B2M		D4BU		623P4	616P	M1A	4010D or 4228G	35E4A
702DM	‡‡		None §§							4010B or 4228F	8A
2702DM	‡‡									4010D or 4228G	35E4A

* Modular and partially modular telephone sets are supplied without cords. Cords must be ordered separately.

† Color suffix applies; see Table A.

‡ Partially modular; handset cord jack only — Line conductors wired directly to set terminals.

§ Includes universal dial number plate.

¶ Factory-equipped with 623D3 jack; converted or repaired with 623D4 jack.

** Assembled sets equipped with fully-assembled dials; separate telephone set bases equipped with dial mechanisms and dial adapter keys. (No color-sensitive parts.)

†† Factory-equipped with 523A3 plug; converted or repaired with 523A4 plug.

‡‡ To order housings refer to specific set practice for comcode numbers.

§§ Only assembled sets available.

TABLE C

**IDENTIFICATION OF TRIMLINE COMPONENTS
AND ASSOCIATED APPARATUS (NOTE 1)**

HAND TEL SET CODE	METHOD OF IDENT.	TEL BASE CODE	WALL JACK OR MTG CORD CODE	HANDSET CORD CODE	BASE HANDSET JACK ADAPTER CODE	HAND TEL SET JACK ADAPTER CODE	METHOD OF PROVIDING TIP PARTY IDENT. GRD
220A or 2220B	Large Handset Cord Jack With Code Stenciled Inside on Shell	AC1, AC1P	630A (AC1P)	H4DB	None	None	H5AA Cord
		AD1	D5AL				
		AC1, AC1P	630A (AC1P)				
		AD2	D4BU	H4DU	231B (AD2)	227D	None Note 3
		AC2, AC2P	630A (AC2P)				
AD2, AD3	D4BU						
220AM or 2220BM	227D Adapter in Handset Jack of a 220A or 2220B	AC1, AC1P	630A (AC1P)	H4DU	231B	227D†	Note 4
		AD1	D5AL				
		AC1, AC1P	630A (AC1P)				
		AD2	D4BU	H4DU	None	227D†	None Note 3
		AC2, AC2P	630A (AC2P)				
AD2, AD3	D4BU						
220AL	LED Printed Under Fingertop. 227D Adapter in Handset Jack	AC1, AC1P	630A (AC1P)	H4DU	231B	227D*	D-180824 Kit of Parts
		AD1	D5AL				
		AC1, AC1P	630A (AC1P)				
		AD2	D4BU	H4DU	231B (AD2)		
		AC2, AC2P	630A (AC2P)				
AD2, AD3	D4BU						
220B or 2220C (Early Version)	(4) Wire Springs in Handset Jack. Square Buttons (2220C) (Minimodular)	AC1, AC1P	630A (AC1P)	H4DU	231B	None	D-180825 Kit of Parts Note 2
		AD1	D5AL				
		AC1, AC1P	630A (AC1P)				
		AD2	D4BU	H4DU	231B (AD2)		
		AC2, AC2P	630A (AC2P)				
AD2, AD3	D4BU						
220C, 226A, 2220C (Late Version) or 2226A	LED Printed under Fingertop (220C and 226A) Square Buttons on Dial (220C and 226A) Minimodular	AC1, AC1P	630A (AC1P)	H4DU	231B	None	
		AD1	D5AL				
		AC1, AC1P	630A (AC1P)				
		AD2	D4BU	H4DU	231A (AD2)		
		AC2, AC2P	630A (AC2P)				
AD2, AD3	D4BU						

* Factory installed.

† Field or service center installed.

- Notes:
1. All TRIMLINE components and apparatus are ordered separately.
 2. The 220B and 2220C (early version) do not require the 282A adapter.
 3. This combination of components can not be wired for tip party identification.
 4. 227D adapter must be removed for tip party identification.

**TABLE D
MANUFACTURED DISCONTINUED TELEPHONE SETS THAT MAY BE CONVERTED USING MODULAR
COMPONENTS**

TELEPHONE SET*	HANDSET CORD JACK	MTG CORD JACK	ADAPTER (WALL SETS)	PLUG (WALL SETS)	TELEPHONE SET*	HANDSET CORD JACK ONLY
500C/D 500E/F 500L/M† 500W/Y 501C/D/F 510A/B† 515B† †† 2500D 2500M 2500Y 2515† ††	616D	623D4			500AD 500R/S 502A/B 503B/C 510E/F 511F/H 513B 514B 529B 2500S 2502B 2503C 2504B 2510F 2511F/N 2514B¶	616D
702B 702D 2702B 2702D	616P	623P4				
554A/B/F‡ 555B‡ †† 556AR/BR‡ 557 559 593BRW	616C		228-Type ‡	523A§	558F/DRW 2558D	616C 616B
2554B‡ 2555B‡ ††	616B		229-Type ‡	523A§	564HC, 565GK/HK 2564HC, 2565GK/HK	616D**

* Housing must be notched to clear any jack installed.

† Mounting cord jack leads must be at least 9 inches. Use D-161488 connectors and M1W straps to extend conductors if necessary.

‡ Adapter not required if basepan has two keyhole shaped ramps along vertical centerline with rectangular plug track in between.

§ Use any type 523A plug with at least the conductors needed to provide the desired service.

¶ Dress jack leads down back of jack frame to avoid hand telephone set key mounting bracket.

** Push top of jack under terminal board. Do not pinch leads.

†† Signaling feature from m-n contacts cannot be provided simultaneously with 2-line service in these telephone sets.

TABLE E

MODULAR CONNECTING BLOCK CONNECTIONS

INSIDE WIRE					CONNECTING BLOCK	
ONE-LINE SERVICE			TWO-LINE SERVICE	WIRE OR LEAD COLOR	TERMINAL	
NO DIAL LIGHT	DIAL LIGHT	1A1, 1A2 KTS			625-TYPE	630A4
Tip	Tip	Tip	Line 1 (T)	Green	G	1
Ring	Ring	Ring	Line 1 (R)	Red	R	2
	TRNSF	A	Line 2 (T)	Black	B	4
Ground*	TRNSF	A1	Line 2 (R)	Yellow	Y	3

*Supply ground for all one-line installations

TABLE F

635A/B CONNECTING BLOCKS (SEE NOTES)

TYPES OF SERVICE AND AVAILABLE FEATURES	TERMINAL DESIGNATIONS AND LEAD FUNCTIONS							
	1	2	3	4	5	6	7	8
Single Line Series	R1			R	T			T1
Single Line Series With "A" Lead Control	R1		A	R	T	A1		T1
Two Lines - One Line Series, One Bridged	R1		T2	R	T	R2		T1

Notes:

1. There are two internal shorting bars in the jack, shorting terminals 1 and 4 and terminals 5 and 8.
2. Insertion of 8-pin plug will open shorting contacts.
3. When using 635B, insertion of 6-pin plug will not affect shorting contacts.

TABLE G
74D CONNECTING BLOCK (SEE NOTE)

TERMINAL STRIP	652A6 JACK	
	JACK LEADS	PIN NOS.
1	G	4
2	R	3
3	Y	5
4	BK	2
5	BL	6
6	W	1

Note: The 74D may also be used for other services where 5 or 6 conductors are required, ie, with 28A ringer isolator.

TABLE H
FASTENERS FOR 630A4 CONNECTING BLOCK (NOTE 1)

TO FASTEN CONNECTING BLOCK TO WALL (Note 4)	USE TWO (2) EACH OF FASTENERS INDICATED				
	FLAT HEAD NO. 6-32 MACHINE SCREW		B WALL ANCHOR SIZE 4 OR 6	D PLASTIC ANCHOR SIZE 10	NO. 8-15 BY 1 IN. FLAT HEAD TAPPING SCREW, TYPE AB (NOTE 3)
	3/16" OR 5/16"	3/4"			
1034A Mtg Plate	X				
63-Type Bracket, Device Box, Plaster Ring		X			
Stucco or Plaster on Wood Lath					X
Plaster on Metal Lath, Paneling on Furring Strips, or Plasterboard on Studs			*(Note 2)		X
Hollow Masonry			X(Note 2)		
Solid Masonry				X	X

* Alternate Fasteners

Notes:

1. If connecting block is not securely fastened to the wall with the recommended number of fasteners, additional fasteners should be used.
2. Use size 4 anchors for walls up to 5/8-inch thick and size 6 anchors for wall from 5/8-inch to 1-1/4 inch thick.
3. Or other available screw of equivalent (or greater) size, and thread engagement.
4. Fill any opening in the wall to prevent "chimney" effect which draws dirt into wall sets.